



ACE-DCP Series Multifunction Panel Meter



INDEX

1. Introduction :
2. Features :
3. Switch Description :
4. Edit Mode Description :
5. Setting / Configuration Modes :
6. Dimensional Details :

1. Introduction :

Micro-controller based design to monitor and protect from unhealthy DC voltage (eg. under voltage & over voltage)

ACE DCP meters are compact digital power meter, equipped with customized 4 digit, 1 row alphanumeric display. Four navigator keys & alphanumeric digits simplifies display & configuration of meter.

2. Features :

- True RMS Measurement.
- Micro-controller Based Design With SMD Technology.
- Auxiliary SMPS supply with input range 35-300V AC/DC.
- Password protection for user programmable parameters.
- Programmable Fail Safe & Non Fail Safe Mode.
- Programmable Trip Time Delay & Reset Time Delay
- Trip Indication For Over / Under Voltage faults in the front panel.
- Separate SPDT Relay for over voltage & under voltage. (5A Resistive Contacts)
- Din Rail Mounting (35mm)
- Terminations - Screw Type

3. Switch Description :

Switch	Function
Increment	In Edit mode, increment the value of parameter under programming mode.
Decrement	In Edit mode, decrement the value of parameter under programming mode.
Forward	Select the next parameter to be programmed in programming mode.
Backward	To enter the programming mode, press decrement and backward switch together.

4. Edit Mode :

Display	Description	Range
OV	DC over voltage.	
220	Voltage above which trip led turns on & over voltage relay will trip.	050-300
H OV	Hysteresis Over Voltage	
05	Hysteresis Voltage for resetting the over voltage trip.	02-20
OV d	Over Voltage Delay	
005	Time taken by the OV relay to sense over voltage trip.	001-999
UV	DC Under Voltage.	
180	Voltage below which trip led turns on & under voltage relay will trip.	050-300
H UV	Hysteresis Under Voltage	
05	Hysteresis Voltage for resetting the under voltage trip.	02-20
UV d	Under Voltage Delay	
005	Time taken by the UV relay to sense under voltage trip.	001-999
RSTd	Under / Over voltage reset delay.	
005	Reset delay for resetting the under / over voltage trip if the unit is in healthy condition.	001-999
UV FS	Under voltage Fail Safe Mode	
FS	Fail Safe Mode: Under voltage function will be activated as soon as the unit is power on. Non Fail Safe Mode: Under voltage function will be activated once the dc voltage pick up the under voltage setting.	FS / NFS

5 . Setting/Configuration Modes :

5.1 EDIT Mode : Parameter values can be changed in 'EDIT' mode, 'EDIT' mode is password protected.

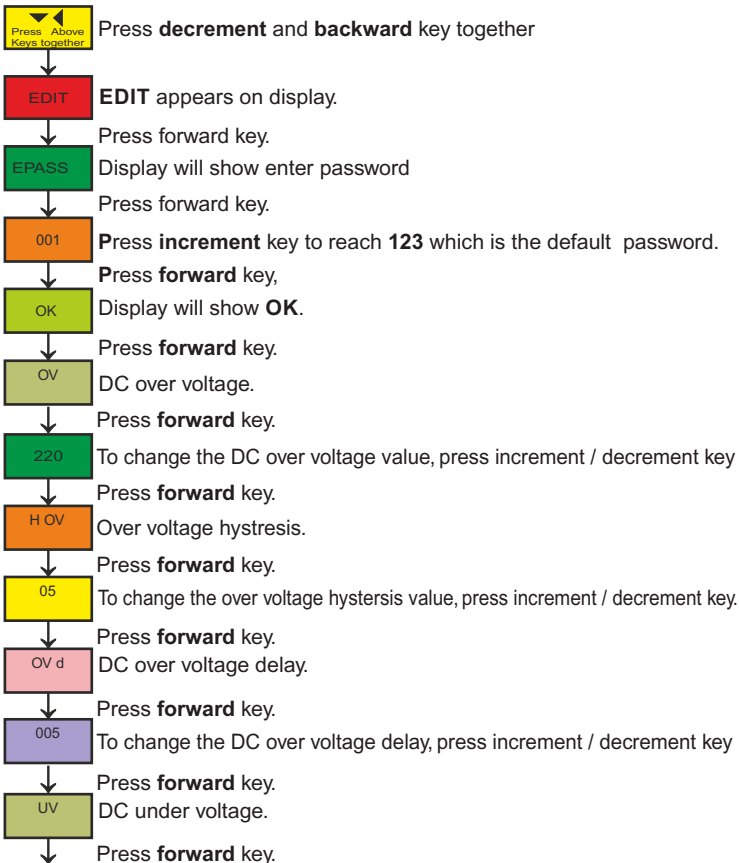

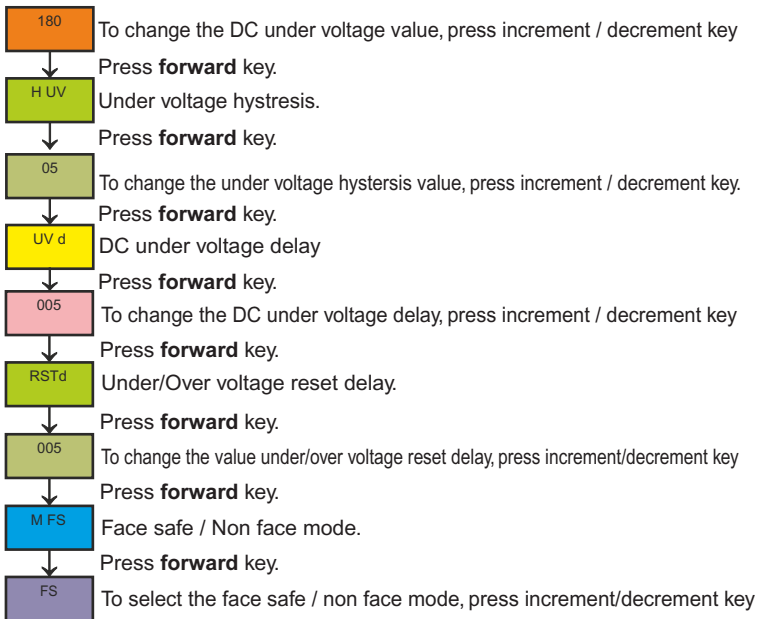

5.2 View Mode: User can view all set values in this mode without entering password Change of values is not permitted in this mode.

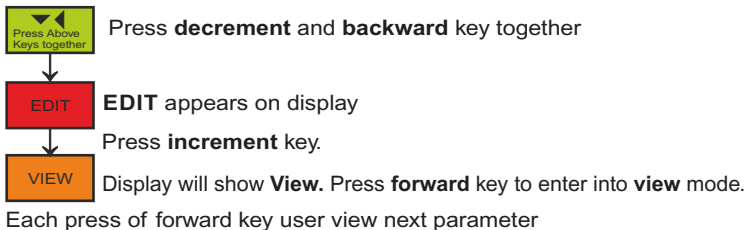

Each press of forward key user view next parameter

5.3 RST Password :

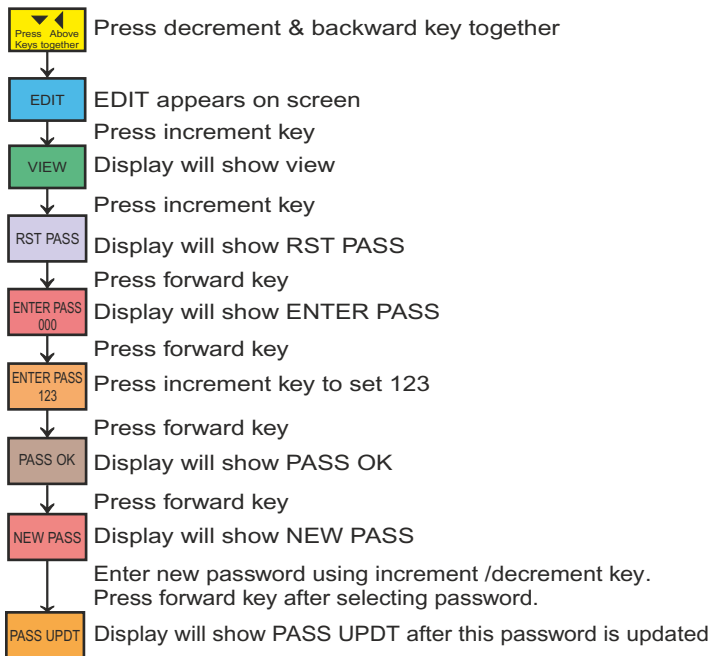

New password can be programmed in this mode. Once the password is changed, it is not possible to retrieve the old password, hence it is recommended to have a record of new password.

6. Dimensional details :

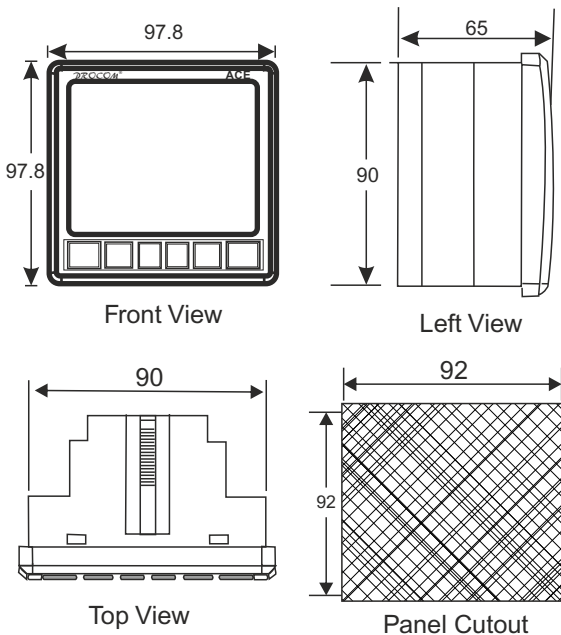

All dimensions are in mm.

MRM **PROCOM**[®] Pvt. Ltd.
Plot No. 20-21, Industrial Estate
Sector-59 (II), HUDA, Faridabad-121004, Haryana
Phone: 0129-4700400 (10 Lines), E-mail : info@mrmprocom.com
Website : www.mrmprocom.com